

# DATA SHEET

## JET-2™ Centrifugal Blower by JETAIR™

The JET-2™ is ideal for airknife drying, vacuum, fluidized bed and aeration applications. The JET-2™ is the most compact centrifugal blower available and fits into the widest range of OEM equipment. All JET-2s™ have DirectDrive™ Technology.

JetAir Technologies' JET-2™ Blower is the first Direct Drive high-speed centrifugal blower. The JET-2™ is engineered for high flow and moderate pressure applications. The JET-2™ fits into the widest range of OEM equipment.

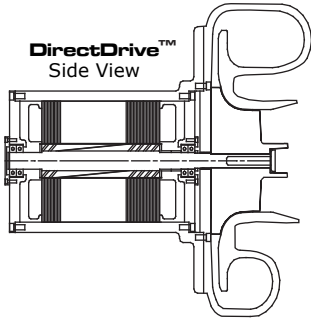

JetAir's DirectDrive™ Technology (US & Int'l. Pat. Pend.) is enabled by a proprietary high-speed motor and an aerodynamically designed blower. DirectDrive™ enhances reliability and boosts performance by eliminating belts, tensioning devices and complex spindle assemblies common in other high-speed blowers.

The JET-2™'s aerodynamic belt-free design and advanced impeller achieve industry leading 80% isentropic efficiency. A JET-2™ is 20% more efficient than our competitors and in many cases, a JetAir 15hp/11kW JET-2™ outperforms a competitors' 20hp/15kW blower!

JetAir offers three complementary blowers lines with DirectDrive™ Technology, the JET-2™, JET-1™- JET-1D™ and JET-3™ Lines. Blower selection is made per customer application requirements.

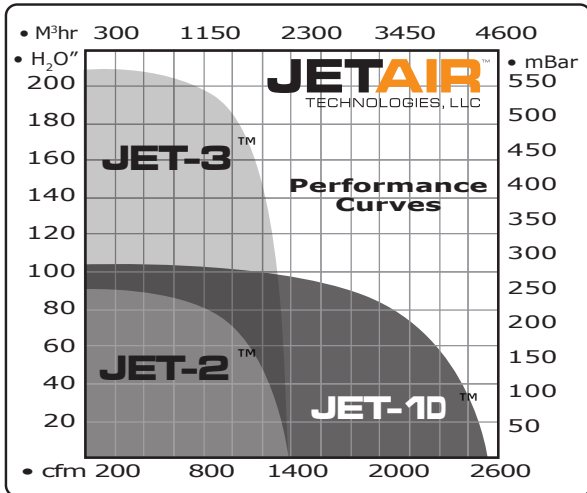

JET-2™s are controlled with Variable Frequency Drives (VFDs). The VFD enables JetAir to "dial in" exact customer air-flow needs without having to waste or bleed-off air like belt drive systems. The VFD also has built-in motor protection and "smart factory" PLC connectivity.

JET-2™ Blowers represent the latest centrifugal technology with industry leading power, efficiency, features and compactness.

Blower and Vacuum Tables and Line Drawings are on reverse side. Contact JetAir for more information.



USA & International  
Patents Pending

### ADVANTAGES. WHY A JET-2?

**EFFICIENT POWER.** JET-2™ is 20% more efficient than belt drive units. Flow: 1350cfm/2300M³Hr; Pressure: 95"/240mBar; Vacuum: 85"/212mBar

**MOST COMPACT.** Smallest Footprint. One Man Install. Fed-X, DHL, and UPS Delivery Available.

**MORE RELIABLE.** Built-in Motor Protection. Ultra-Balanced Motor Shaft. 1 Yr. Warranty, Fewer Parts.

**BETTER ROI.** Most Efficient Power Use. No Belts or Adjustment Costs. Lowest Delivery Costs.

**BETTER SUPPORT.** US and European Facilities. OSHA Compliant dBA. EMI Protection. UL, CUL, CE, C-Tick, NSF and ISO 9000 Standards.

# JETAIR™

TECHNOLOGIES, LLC

1884 Eastman Ave., #112, Ventura CA 93003  
805-654-7000 main, 805-654-7064 facsimile  
www.jetairtech.com or sales@jetairtech.com

# Technical Specifications

## JET-2™ High-Speed Centrifugal Blower

DESCRIPTION: DirectDrive™ Technology, Single Stage Centrifugal Compressor, Oil-Less, Spindle Free Design.

DRIVE SYSTEM: DirectDrive™ Technology, with Variable Frequency Drive Control. Integrated Motor Protection, Air Cooled Rated: 150°F[60°C]

IMPELLER: 5 Axis C355 Aluminium

AERO-BLOWER: A356-T6 Aluminum with Integrated Lifting Eye.

HIGH-SPEED MOTOR: TEFC - IP54, Ext. Terminal Box, 3 Phase Connections, 190-600V, 50-60Hz., 5HP[4kW]-20HP[15kW], includes Variable Frequency Drive - IP20.

5HP [4kW]	P/N 40060
7.5HP [5.5kW]	P/N 40061
10HP [7.5kW]	P/N 40062
15HP [11kW]	P/N 40063
20HP [15kW]	P/N 40064

WEIGHT: 79lbs.[36kg]

CONNECTIONS: Inlet 5"Ø [125mm], Outlet 4"Ø [102mm], 360° Rotation.

FILTER ASSEMBLY: Filter, Assembly to mount filter to blower. (Assembly is purchased once with blower.)

Std. 5 Micron Polyester	P/N 30000
5 Micron Paper	P/N 30001
HEPA	P/N 30002

REPLACEMENT FILTER ELEMENTS:

Std. 5 Micron Polyester	P/N 30050
5 Micron Paper	P/N 30051
HEPA	P/N 30052

ENCLOSURES: IP66 Stainless Steel Washdown Enclosures, includes built-in filter Assembly.

Blower, Filter Assembly	P/N 50100
Blower, VFD, Filter and Gage	P/N 50110

WARRANTY: 1 Year.

US & International Patents Pending  
EC Letter of Conformity



© 2005 JetAir Technologies, LLC Specifications subject to change.

## JET-2™ Blower & Vacuum Performance Chart

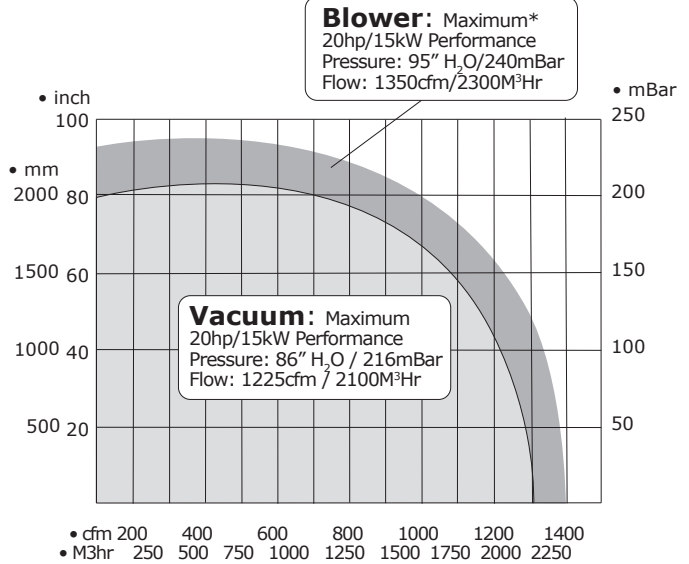

Tested per ASME PCT-10 & ISO 58

## Model JET-2™

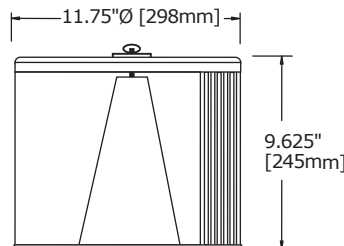
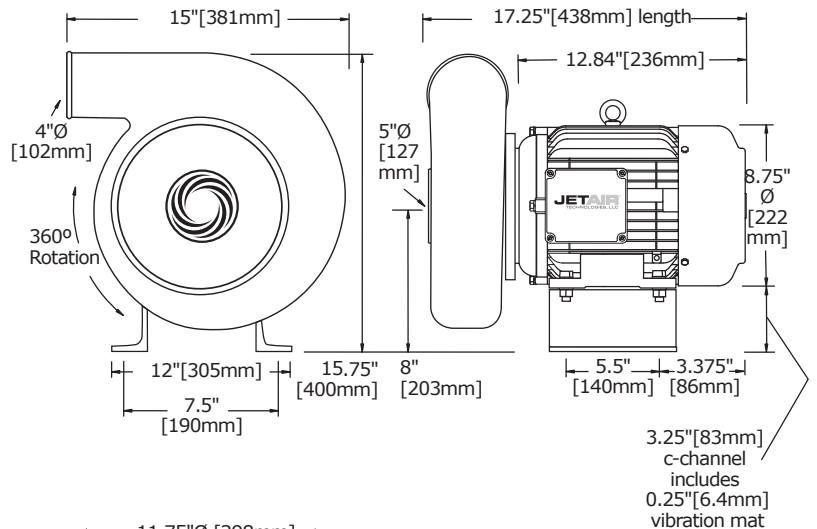

**JET-2™ Replacement Filter. Requires Filter Assembly.**

# JETAIR™

TECHNOLOGIES, LLC

1884 Eastman Ave., #112, Ventura CA 93003  
805-654-7000 main, 805-654-7064 facsimile  
www.jetairtech.com or sales@jetairtech.com